



HEXAGON

ELECTRIC AUTOSTEERING Installation Manual



23 May 2022

Introduction

This manual contains important information on how to install the electric autopilot.

- Carefully read this installation manual before turning on the equipment;
- To ensure your safety, please observe the instructions contained in this manual and the agricultural machinery manual.

The symbols used in this manual have the following meanings:

Type	Description
 DANGER	Indicates an imminently hazardous situation, which, if not avoided, will result in death or serious injury.
 WARNING	Indicates a potentially hazardous situation or misuse, which, if not avoided, may result in minor or moderate injury, material or financial loss and environmental damage, or all of them.
 IMPORTANT	Important information that should be observed, so that the equipment is used in a technically correct and efficient way.

Content

1	Safety Information	5
2	Installation Overview	6
2.1	General Diagram.....	6
2.1.1	Ti10 Diagram.....	6
2.1.2	Ti7 Diagram.....	7
2.1.3	Ti5 Diagram.....	8
2.2	Important Notes.....	8
2.3	Preparing the Vehicle for Installation.....	9
2.4	Required Components.....	9
2.4.1	Toolkit.....	9
2.4.2	Hexagon Electric Autopilot Kit	9
2.4.3	Anti-Rotation Bracket.....	9
3	Mechanical System Installation	10
3.1	Removing the Steering Column.....	10
3.2	Mounting the Flange	10
3.3	Mounting the Anti-Rotation Kit.....	11
3.3.1	Examples of Anti-rotation Kit Models	13
3.3.2	Examples of Mounted Anti-rotation Kits	14
3.3.3	Driver Install	14
4	Electric System Installation.....	15
4.1	Harness Install	15
4.2	Electric Diagram.....	15
4.2.1	Diagram of the 03300 Harness.....	16
4.3	Driver Pinout	17
5	Settings	18
5.1	Basic Settings	18
5.1.1	Support Mode.....	18
5.1.2	Checking Activations	19
5.1.3	Vehicle Configuration.....	20
5.2	Autosteering Settings Menu	21
5.3	Support Mode.....	22



- 5.4 Testes..... 23
 - 5.4.1 HexDrive Installation - Dead Band Test..... 23
 - 5.4.2 HexDrive Installation Gain Adjustment..... 24
- 5.5 INS Installation 25
- 5.6 Calibration 26
 - 5.6.1 Driver Calibration 26
 - 5.6.2 Accelerometer Calibration 28
 - 5.6.3 Gyroscope Calibration 29
 - 5.6.4 Wheels Alignment Calibration 30
 - 5.6.5 Clockwise and Counter Clockwise Calibration..... 30
- 5.7 Autopilot General Configurations..... 32
- 5.8 Controls 33
 - 5.8.1 Overshoot..... 34
 - 5.8.2 Aggressiveness..... 34
 - 5.8.3 Sensitivity 34
 - 5.8.4 Speed Gain (%) 35
 - 5.8.5 Curve Aggressivity 35
 - 5.8.6 Techniques and Recommendations for Adjustment..... 36
- 6 Operation 37**
- 6.1 Autopilot Status..... 37
- 7 Problems and Solutions..... 38**

1 Safety Information

The following instructions are intended to inform users about the risks inherent to the installation of the Autopilot and how to avoid them.



The following personal protective equipment are mandatory during the installation:

- Gloves for handling sharp or abrasive materials;
 - Protective glasses for handling contents or system under hydraulic pressure;
 - Boots to work in wet locations ditches and swamps or when in contact with chemicals
-



Whenever the vehicle is in operation, parts of the vehicle, including the engine and exhaust systems may be extremely hot and can cause serious burns. To avoid burns, wait for these hot parts to cool down before starting to work with them



Avoid wearing loose clothing and/or chains around the equipment containing movable, loose or irregular parts as they can hold and cause injuries.



The Remove the ignition key and place a protective plate "Do not operate" in the cabin when you are working in order to avoid serious or fatal injury



The Agricultural machinery may have been exposed to many types of chemicals. Any chemical or waste, must be removed from the agricultural vehicle before starting any work:

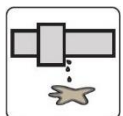

The Use extreme caution when working with pressurized systems (air, water, oil). Release all the system pressure before disconnecting any fixture. Use a cloth, or other obstruction to divert possible leakage. Always wear gloves, NEVER use your bare hands. To find or check for leaks use a cardboard



The installation process may put you in contact with hazardous substances, like oils, which may cause poisoning. Thoroughly wash your hands after you finish working:

**DANGER**

Unauthorized modification of the vehicle for assembly or installation of the product may alter the function and safety of agricultural machinery:

**DANGER**

Battery terminals and related accessories may contain lead, which can cause serious illnesses. To avoid lead ingestion, wash your hands immediately after any contact with the battery:

2 Installation Overview

⚠ WARNING

The Hexagon Electric Autopilot is intended exclusively for agricultural use, in an open field with agricultural vehicles approved by the manufacturer for electric autopilot use. It may not be used, under any circumstances, with any other type of vehicle, or for any other purpose.

2.1 General Diagram

The autopilot structure is composed of a monitor, an ECU (driver), harness and the electric autopilot assembly. A general diagram is shown in the following picture, where you can see how the elements are connected to each other.

2.1.1 Ti10 Diagram

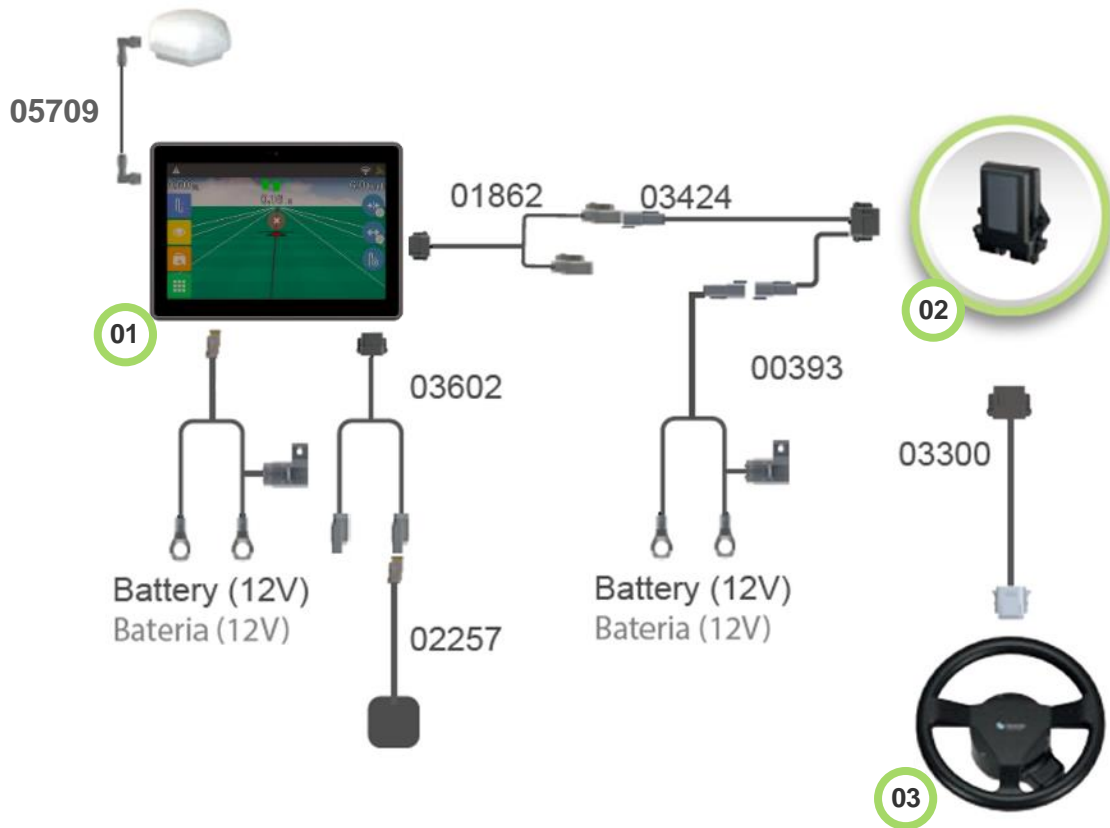

Identification	Code	Description
1		Ti10 with autopilot activation.
2	03916	Autopilot Driver (ECU)
3	05752	Motor Track Controller Electric Autopilot v1.3.2

2.1.2 Ti7 Diagram

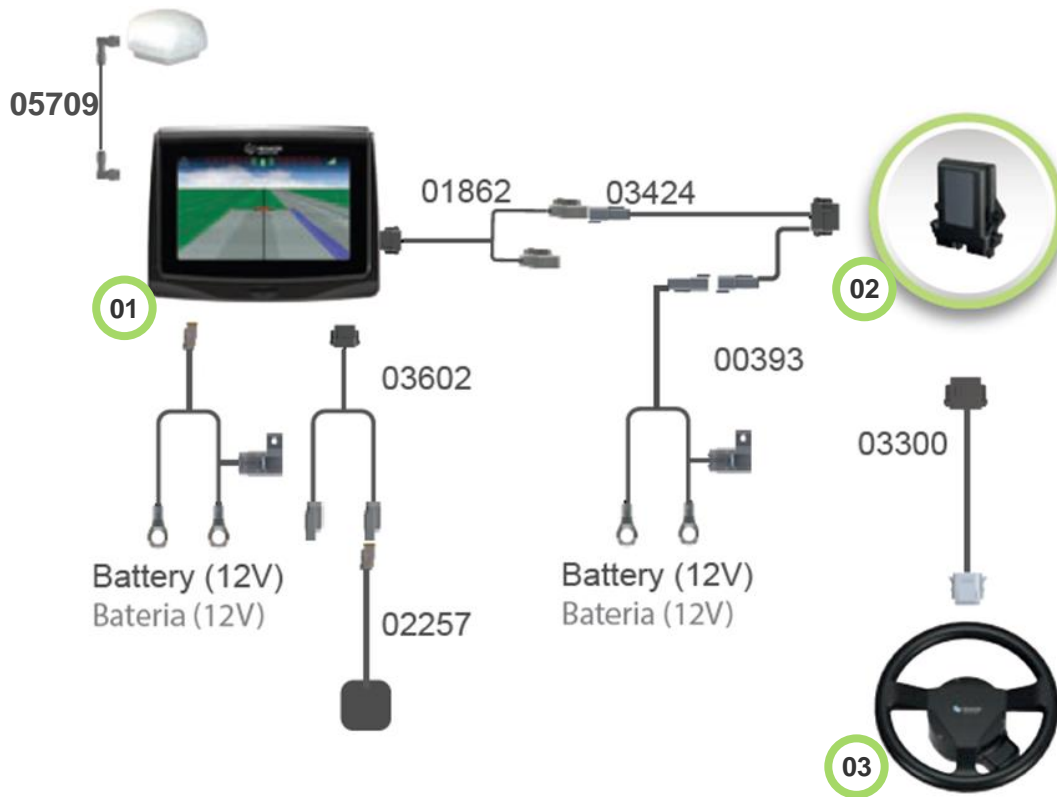

Identification	Code	Description
1		Ti7 with activation for Auto Steering
2	03916	Autopilot Driver (ECU)
3	05752	Motor Track Controller Electric Autopilot v1.3.2

2.1.3 Ti5 Diagram

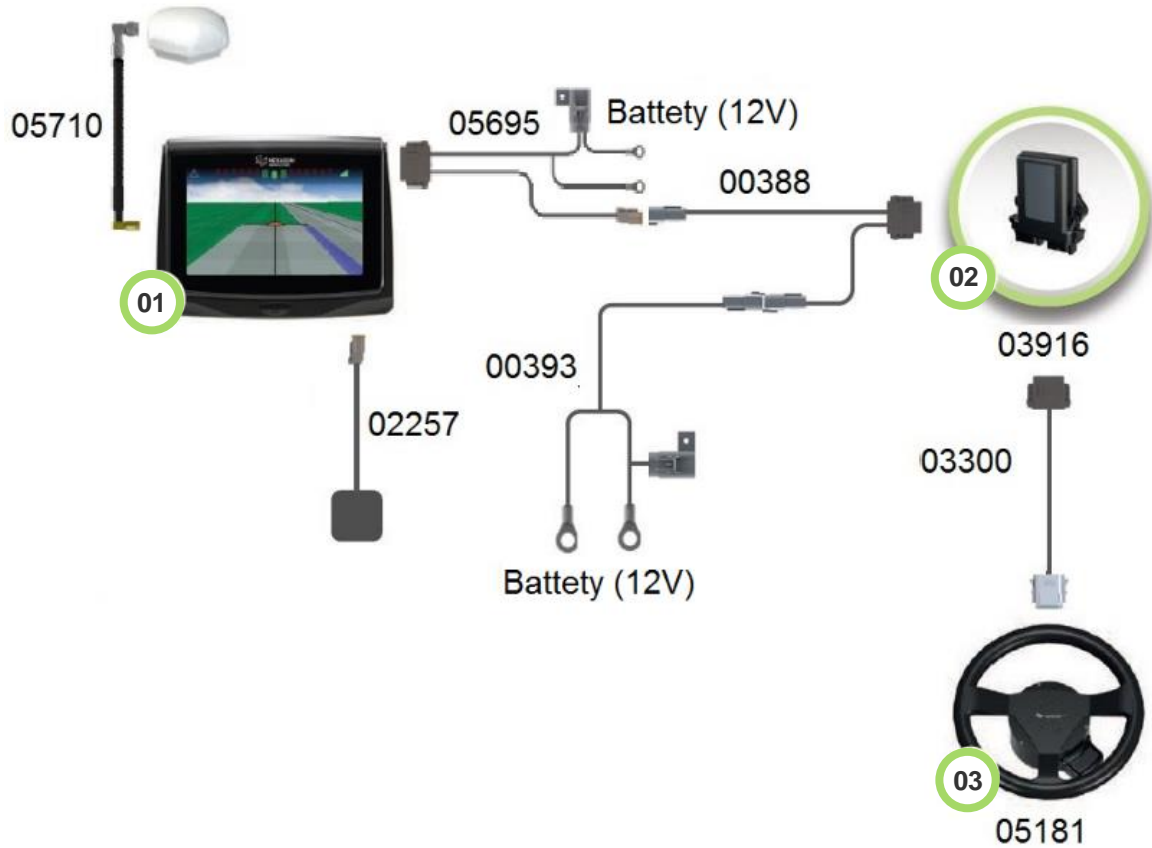

Identification	Code	Description
1		Ti5 with activation for Auto Steering
2	03916	Autopilot Driver (ECU)
3	05752	Motor Track Controller Electric Autopilot v1.3.2

2.2 Important Notes

For reference on other important components, which will vary according to the model of the steering column (anti-rotation) and the vehicle's steering wheel axle (flange), it is extremely important to consult the Documents Folder and/or files in the links below, to ensure that you have the correct model of anti-rotation and flange.

Documents Folder: [Hexdrive](#)

File One: [Hexdrive Anti-Rotation Kits Assembly Guide 02.05.22.pdf](#)

File Two: [Kits Anti-Rotation for Track Controller 06.11.2022.pdf](#)

 **IMPORTANT**

NOTE: Regarding the Software content presented here, this manual is based on the Version SW 3.19.1 LTS for the display and firmware Version FW 2.19.1 for the Autopilot ECU (Driver).

Always check the versions that come with the material you will be receiving. Consult the website for more information: <https://hexagonagriculture.com/support>

2.3 Preparing the Vehicle for Installation

- Park the vehicle on a hard and flat surface;
- Engage the parking brake and remove the key from ignition;
- In an articulated vehicle install the hinge locks;
- Remove dirt from areas where the system is installed;
- Open the boxes of the kits in a clean place;
- Check the items in the box with the materials list.

2.4 Required Components

2.4.1 Toolkit

- 27mm socket wrench with an extension. Note: this socket size may not be compatible with all vehicle models;
- 10mm wrench;
- 2,5mm Allen wrench;
- 5mm Allen wrench.

2.4.2 Hexagon Electric Autopilot Kit

Code	Description
05752	Track Controller Motor Electric Pilot v1.3.2
03424	Adapter Harness DTM06-12S-C CAN + External Power
00393	External Power Cable 5m (battery)
03300	Electric Autopilot Harness
03661	M4x16mm Socket-Head Cap Hex Screw
05181	Autopilot Steering Wheel
03916	ECU - Electric Autopilot Driver 3.3.X

2.4.3 Anti-Rotation Bracket

Code	Description
01227	M6x30 Hex Head Stainless Steel Bolt
01389	M6 Inox Locking Nut
02325	M5 Stainless Spring Lock Washer
02896	M5x10 Socket-head Cap Hex Screw
03291	Anti-rotation Basis
03292	Anti-rotation Male
03293	Anti-rotation Female

3 Mechanical System Installation

i IMPORTANT

The right and left side of the vehicle are referenced being behind the vehicle looking in the normal direction of travel.

3.1 Removing the Steering Column

STEP 1

Remove the center cover of the steering wheel with the help of a screwdriver and then use the 27mm deep socket wrench to remove the nut and the flat washer from the steering wheel. Save both for later use.

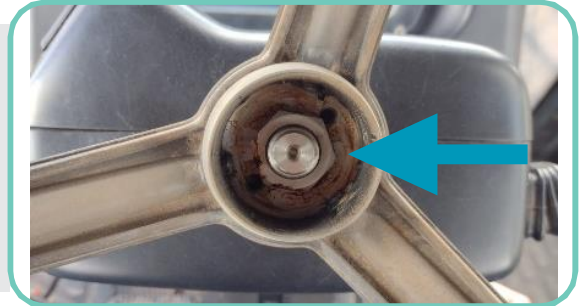

STEP 2

Remove the steering wheel from the steering column. For convenience, use a steering wheel puller, or a pulley puller to remove the steering wheel.



3.2 Mounting the Flange

STEP 1

Select the flange according to the shaft type.

Check the proper fit of the selected model to the steering wheel shaft and the way it will be mounted on the hexdrive, normal or inverted.

Note: consult the documents mentioned above, which contain the main flange and anti-rotation models.



STEP 2

Use a 2,5mm Allen wrench to screw the selected flange with the 03661 screws to the Hexagon Electric Motor Track Controller.

⚠ WARNING Use a medium strength threadlocker for the screws



3.3 Mounting the Anti-Rotation Kit

STEP 1

Select the anti-rotation bracket according to the steering column of the vehicle.

Note: Model 03410 will be used for demonstration.

Consult the documents in the links cited above, for more examples of anti-rotation kits and how they are installed.

STEP 2

Attach the bracket (03410) to the steering wheel column axle. Use the bolts, nuts, and washers from Kit (03733) for fixing it. The positioning of the bracket may vary depending on the vehicle.

STEP 3

Fit the Electric Tracker Controller on the steering column to see the best positioning of the Anti-rotation system.

STEP 4

Position the motor so that the connector does not hit the vehicle's dashboard. Put on the anti-rotation system to check the best positioning.



STEP 5

Screw the base of the anti-rotation system to the bracket.

Material: 2x M5x16mm screws
2x M5 spring washers
2x M5 locking nuts
1x Anti-rotation Base

**STEP 6**

Screw the pin into the anti-rotation base of the bracket.

NOTE: Do not over tighten the screw 01227 to allow movement of part 03292.

**STEP 7**

Screw part 03293 onto Electric Motor Track Controller in the position defined in step 3. Use the M5 spring washer to tighten the anti-rotation system base onto the Tracker Controller.

**STEP 8**

Attach the Electric Motor Tracker Controller to the vehicle's steering column. Put the washer (if any) and the vehicle's original nut. Tighten the nut with the 27 mm socket wrench. NOTE: The two parts of the anti-rotation system must be connected.

**STEP 9**

Use the 10 mm wrench and the hex Allen wrench to tighten the screws of the anti-rotation system.

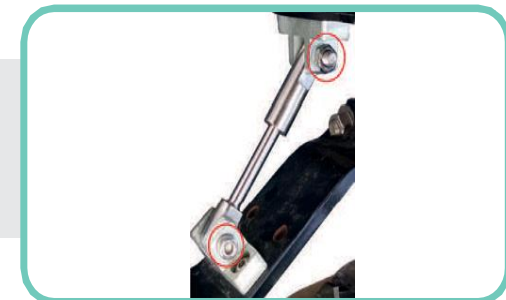

STEP 10

Connect the 03300 harness to the Electric Motor Tracker Controller.

⚠ WARNING Make sure that the connector on the electric motor is correctly locked (click).

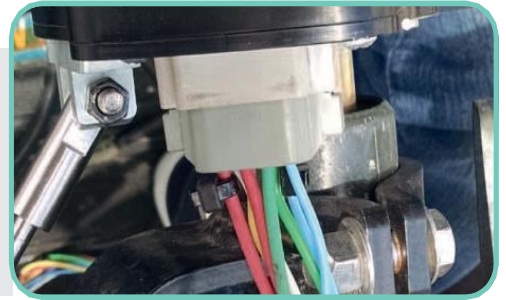

STEP 11

Screw the steering wheel (05181) on the Tracker Controller with the M4x10mm (03288) screws.

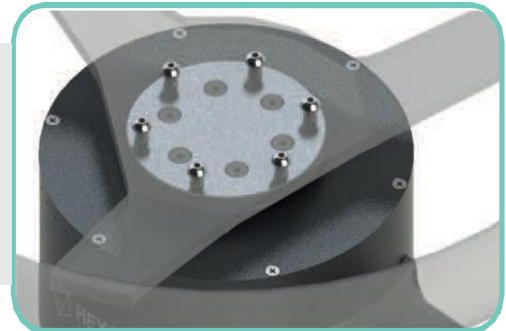
⚠ WARNING Use a medium-strength threadlocker

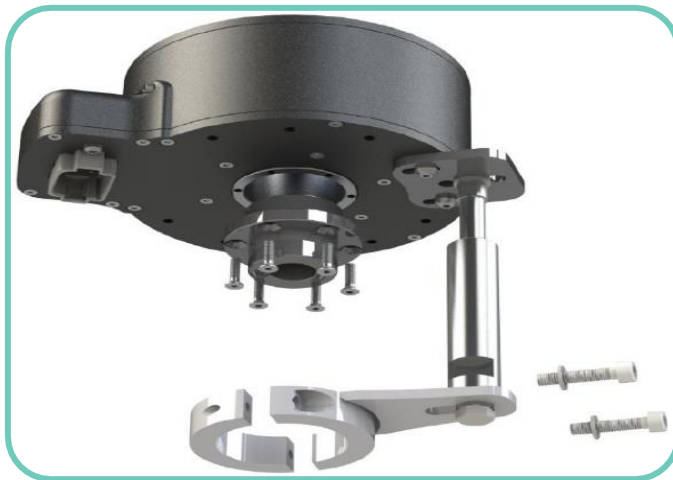

3.3.1 Examples of Anti-rotation Kit Models



04617 - Anti-rotation Kit - 005

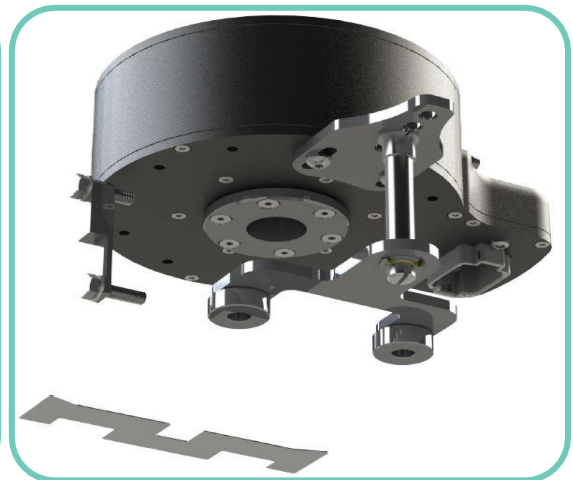

03945 - Anti-rotation Kit - 002

3.3.2 Examples of Mounted Anti-rotation Kits

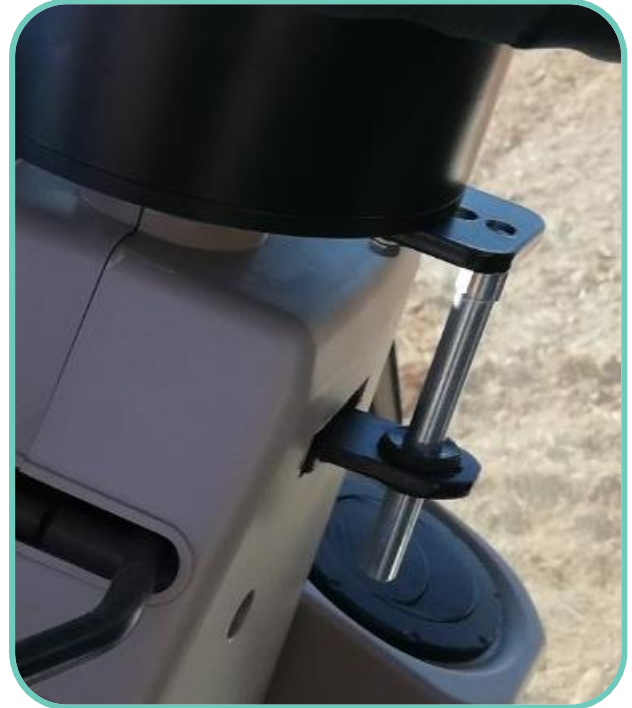

3.3.3 Driver Install

⚠ WARNING

The Driver must be installed on the same structure as the antenna (vehicle frame) and the closer to the rear axle of the vehicle as possible, so that both the driver and antenna will be receiving the same balancing.

⚠ WARNING

Do not attach the driver to surfaces subject to excessive vibration (next to the vehicle's engine), or on tilted surfaces. Prioritize installation in the **Horizontal front** position, on the vehicle floor ([see topic 5.6.1 for reference](#)).

STEP 1

Make two drillings of 6,5mm on a flat surface of the vehicle, following the measurement presented here.

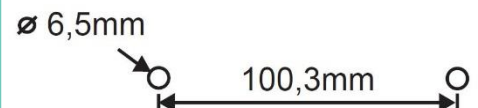

STEP 2

Screw the driver on the tractor with the M6X30 screws and washers. Use the M6 locking nut for fixing it.

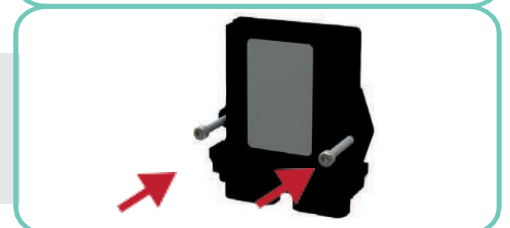

4 Electric System Installation

4.1 Harness Install

Item	Code	Description
Battery Power Cable 7m – Ti10	06960	Power cable with a 10A fuse for kit with the Ti10 display
Battery Power Cable 7m – Ti7	05697	Power cable with a 10A fuse for kit with the Ti7 display
Battery Power Cable + CAN + Maneuver 7m - Ti5	05695	Power harness with 10A fuse for kit with the Ti5 display + CAN harness + Maneuver harness
CAN Harness	01862	Main CAN harness (CAN network).
Antenna cable 7m for Ti10 and Ti7	05709	Cable RG58 7m TNC male 90 degree angle + TNC male 90 degree angle– TM58U-TM001-18-02
Antenna cable 7m for Ti5		Cable RF TNC-SMA RA RG58 7m - Ti5 Display
Kit Foot Switch DTM04-2P connector	02257	Foot switch with cable.
Battery Power Cable 5m	00393	External power for the Autopilot's Driver.
Cable Adapter DTM06-12S-C CAN + External Power.	03424	Harness connected to the Driver to receive the CAN from the display and the external power from the vehicle's battery.
Harness Electric Autopilot	03300	Harness connecting the Driver with the Tracker Controller Electric Autopilot.

4.2 Electric Diagram



The To avoid damage or malfunction of the harness:

- Pass the cables away from areas where they may get pinched or rubbed against one another.
- Do not change the lengths of the cables and connections. If you need to change the power cord length, do not remove the fuse or the cable fuse holder.



4.2.1 Diagram of the 03300 Harness

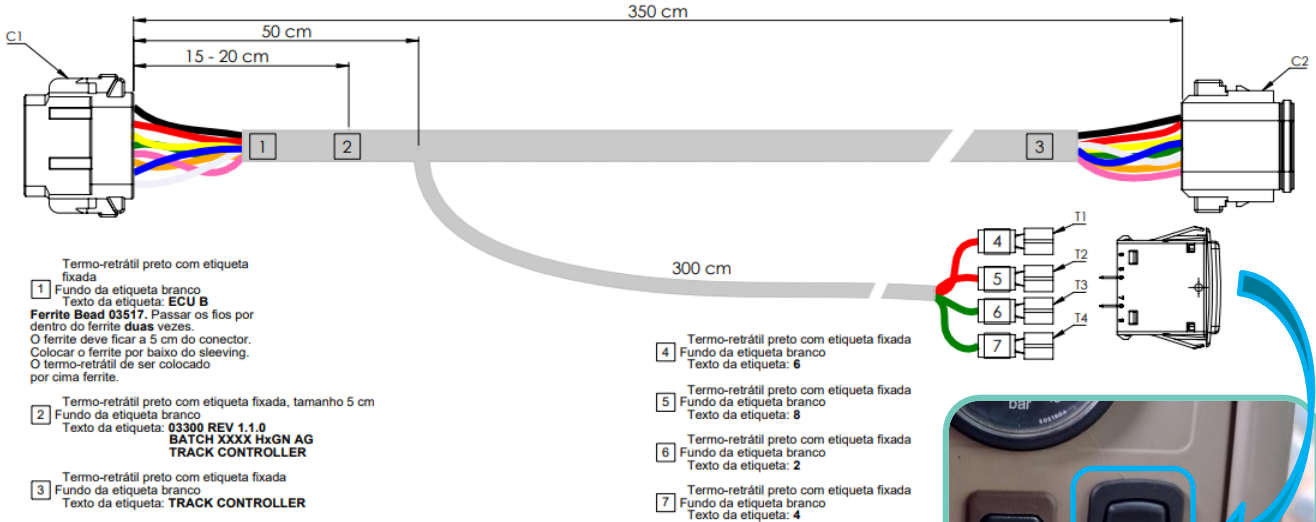
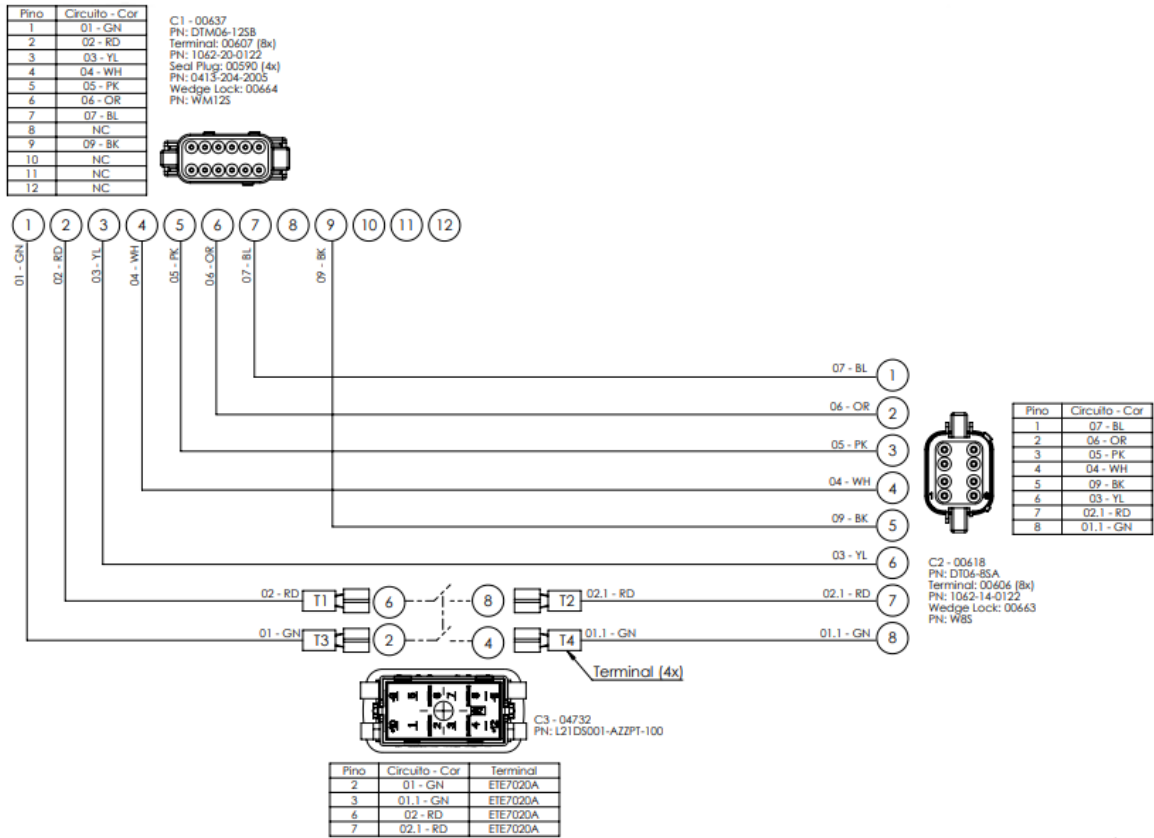

Main Shut off Key



4.3 Driver Pinout

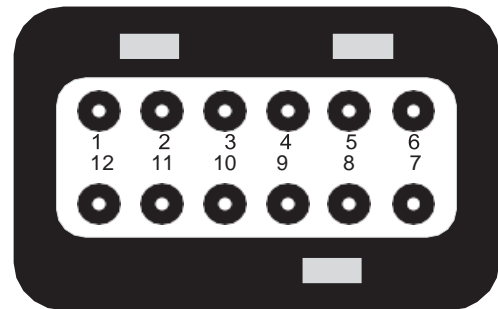
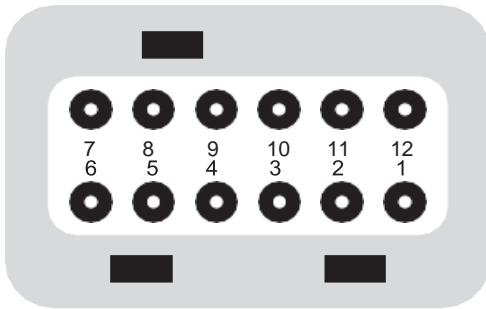

Connector gray (A)	
1	Ground
2	CAN CON P
3	Ground
4	Ground
5	Sensor 2
6	Ground
7	Out 5/12V A
8	Sensor 1
9	Out 5/12V B
10	V Aux +
11	CAN CON N
12	BAT +

Connector black (B)	
1	Motor C
2	Motor B
3	Motor A
4	Out 5/12V C
5	Sensor C (In)
6	Sensor B (In)
7	Sensor A (In)
8	Sensor D (in)
9	Ground
10	V Aux +
11	V Aux +
12	V Aux +

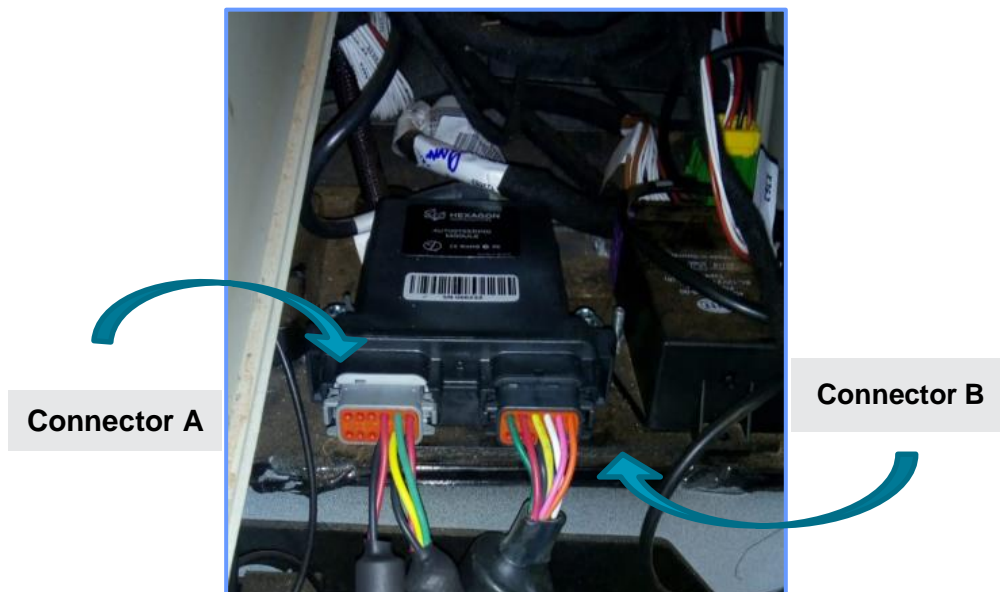

5 Settings

5.1 Basic Settings

5.1.1 Support Mode

IMPORTANT To access advanced settings, it is necessary to enable **Mode Advanced** or the **Support mode**.

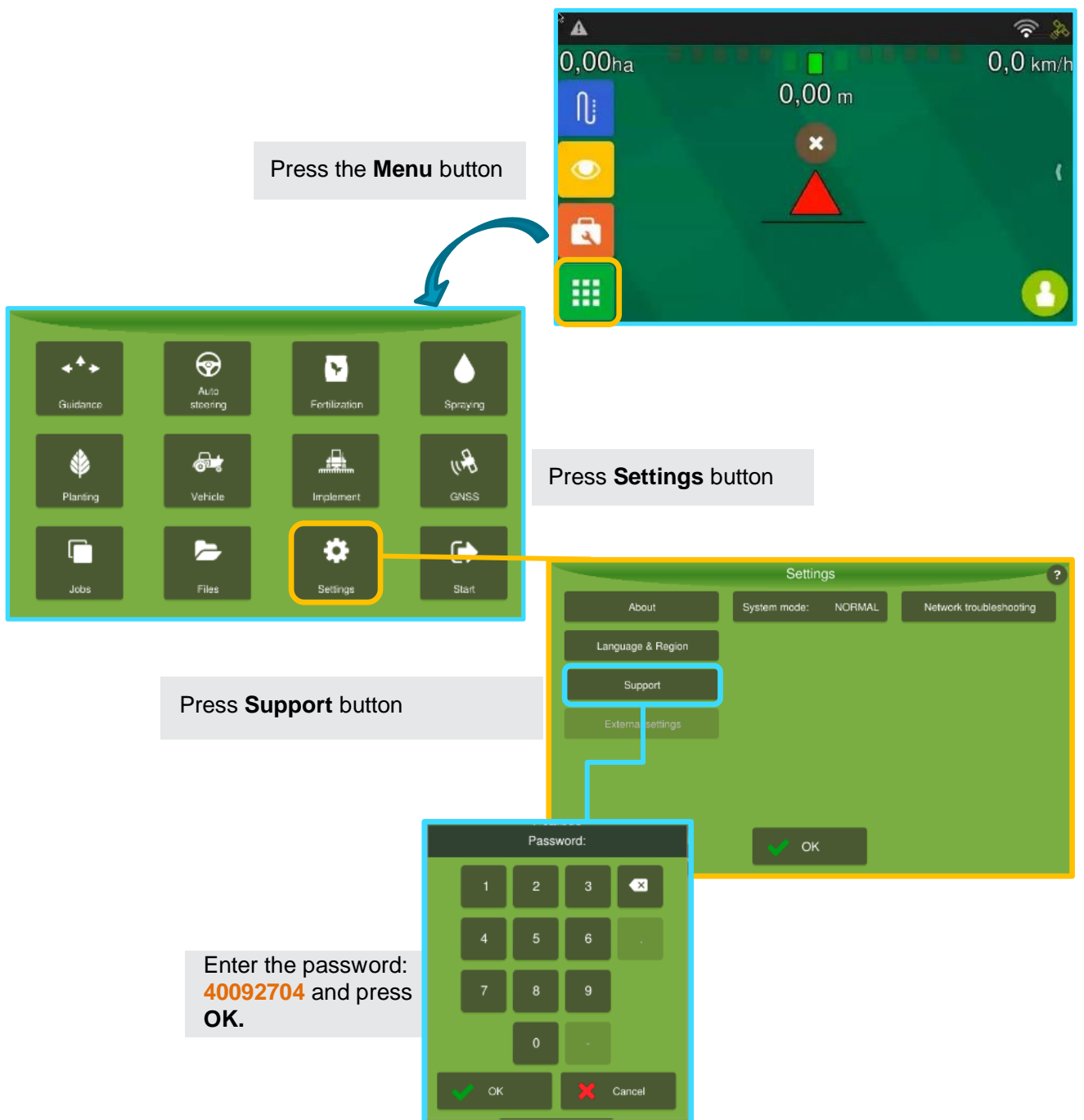

5.1.2 Checking Activations

WARNING

The Driver must be installed on the same structure as the antenna (vehicle frame) and the closer to the rear axle as of the vehicle as possible, so that both the driver and antenna will be receiving the same balancing.

How to check:



The process involves three steps:

- 01** - Press **About** in the **Settings** menu.
- 02** - Press **Show activations** in the **About** screen.
- 03** - Check for **Auto Steering** in the **Enabled features** list.

In the **SETTINGS MENU**:

- 01**- Press **About**.
- 02**- Press **Show activations**.
- 03**- Check for **Auto Steering**, if present, activation for Autosteering is OK.

5.1.3 Vehicle Configuration

 **WARNING**

Whenever you create a new vehicle, all the steps of configuration, calibration and adjustments must be adequately fulfilled. All the measurement must be correct.

In the settings menu, press vehicle. The exact measurements of the vehicle are necessary for the proper functioning of the autopilot. Each vehicle has its own autopilot settings and adjustments (calibration, gains, etc.)

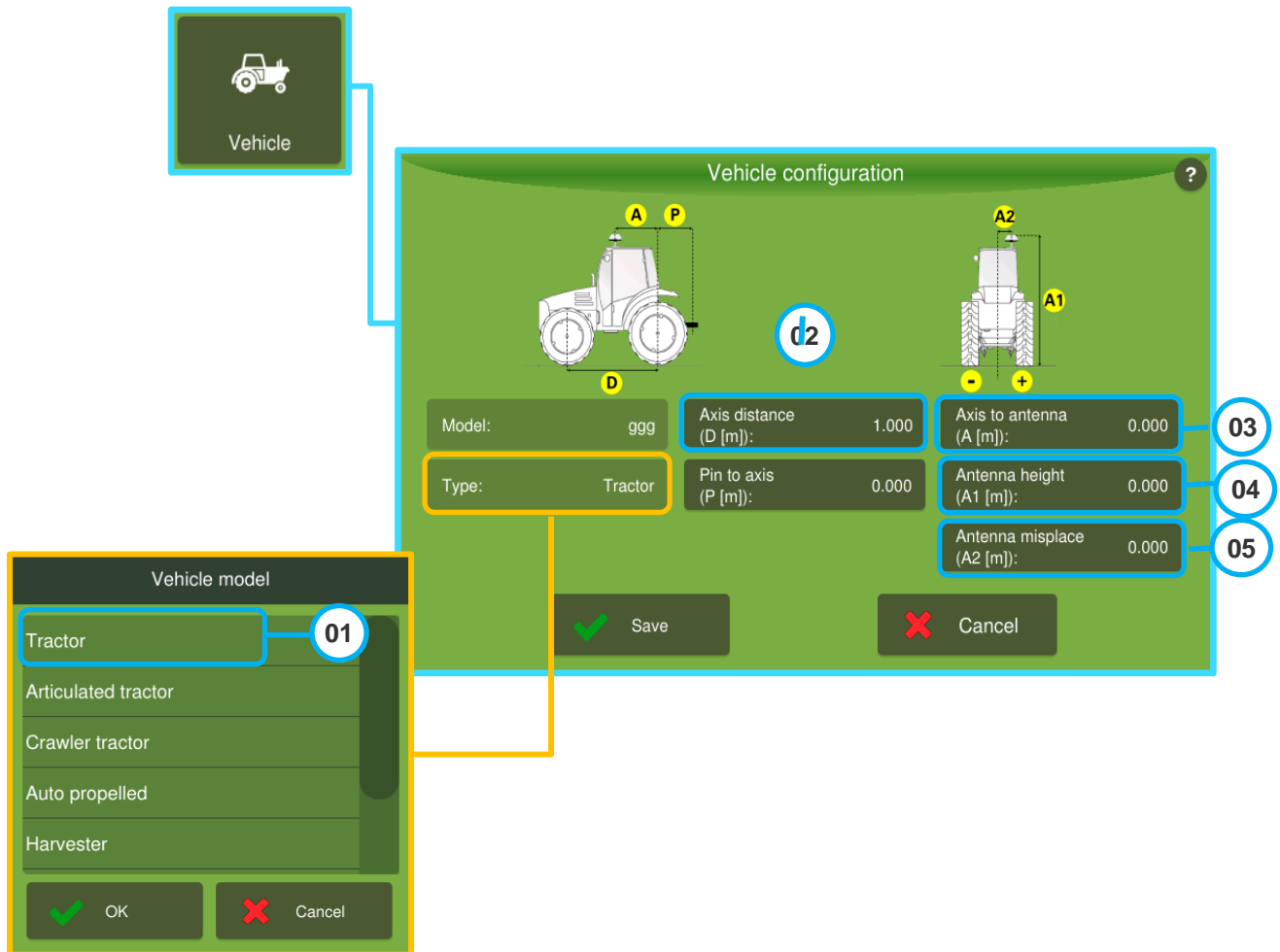

- 1- Select the type/model that matches the vehicle. Each model has a specific layout that needs to be properly selected because of the measurements. Standard Type: Tractor.
Available models: Tractor, Articulated Tractor, Crawler Tractor, Self-propelled, Harvester, Truck, Excavator and Invalid.
- 2- **Axis distance:** Distance, in meters, from the center of the rear axle to the center of the front axle. Fundamental to calculate the control routine.
- 3- **Axis to antenna:** Distance, in meters, from the center of the rear axle to the antenna. Fundamental to the tilt compensation system, for approaching the wayline and working on curved Guidelines.

The antenna should preferably be installed close to the rear axle. It should always be ahead of the rear axle, never behind.

WARNING

Its field of view must be clear of objects (hoods, air-conditioning, cabin, etc.).

The ECU (driver ATCD) and antenna must be installed in the same structure (same buffer) and, if possible, with similar distances from the rear axle.

4- Antenna height: Distance, in meters, from the ground to center of the antenna. This measure is fundamental for the tilt compensation system and parallel lines.

5- Antenna misplace: Distance, in meters, of the lateral offset of the antenna. Fundamental for the parallelism of the lines.

5.2 Autosteering Settings Menu

In the autopilot settings menu we have the following buttons:

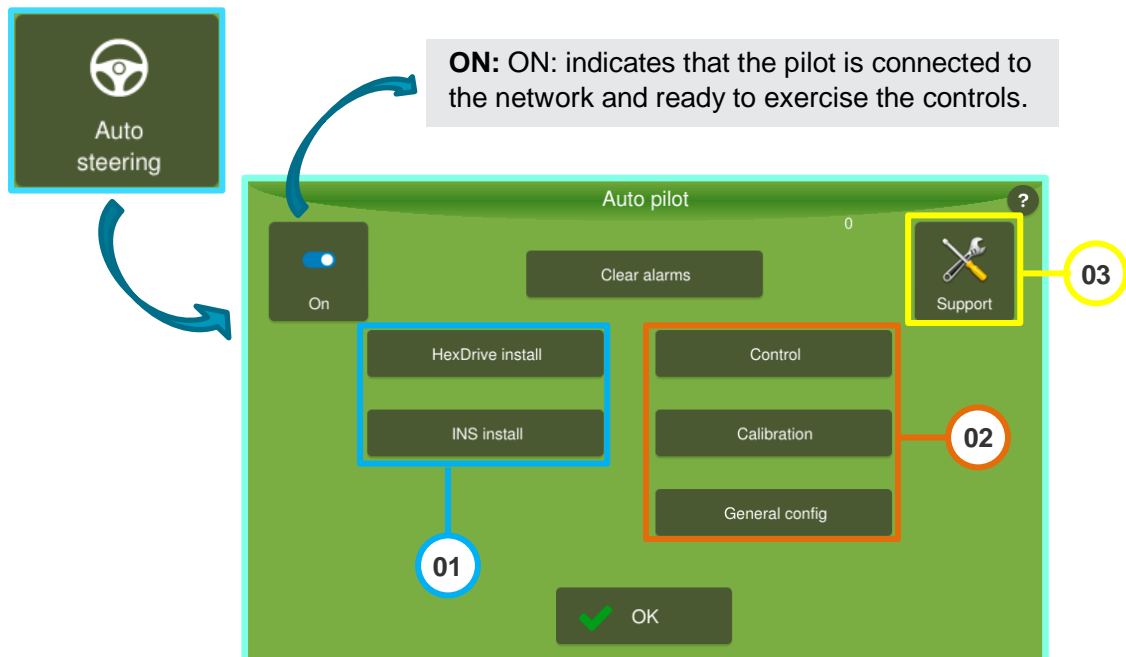

01 - Basic Mode

- HexDrive Install
- INS Install

02 - Advanced Mode

- Control
- Configuration
- General config.

03 - Support Mode

- Support

5.3 Support Mode

IMPORTANT Enter the support menu to make sure that the right autopilot type is selected (Type Pilot: HexDrive).

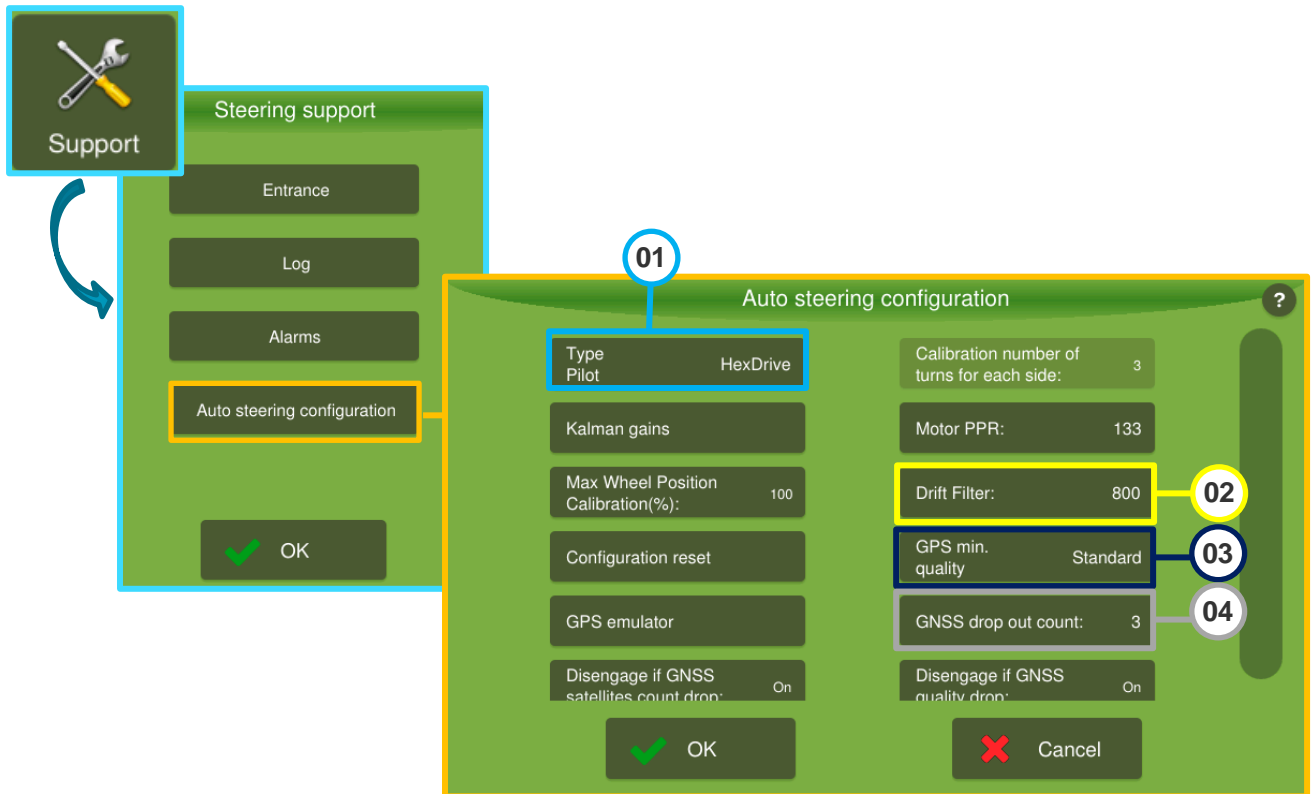

01- Type Pilot: Allows you to select the Autopilot type being installed. In this case, select HexDrive for the Electric Autosteering.

02- Drift Filter: NOTE: For most cases, there is no need to change the value from the standard - 800 -.

With electric autopilot, the wheel position is estimated using a series of information from the gyroscope and GNSS. This reading may contain noise and it is necessary to filter the data to obtain a reliable value. Configure the drift filter to smooth the wheel angle estimation. The lower the value, the autopilot tends to move the wheels more, especially when going through ditches and uphill/downhill changes in the terrain. The higher the value, the more stable it is, but the vehicle tends to zigzag

03- GNSS minimum quality: Allows you to select between four signals type:

- High precision (a more basic precision, using only the Novatel Glide satellite);
- Standard (signal without any kind of correction, with elevated error)
- RTK (2 centimetres, using RTK correction)
- Charged Signal (2.5 absolute centimetres, guaranteed by the TerraStar C PRO from Novatel)

04- GNSS drop out count: Disable the autosteering if it this counting drops below three.

5.4 Testes

5.4.1 HexDrive Installation - Dead Band Test

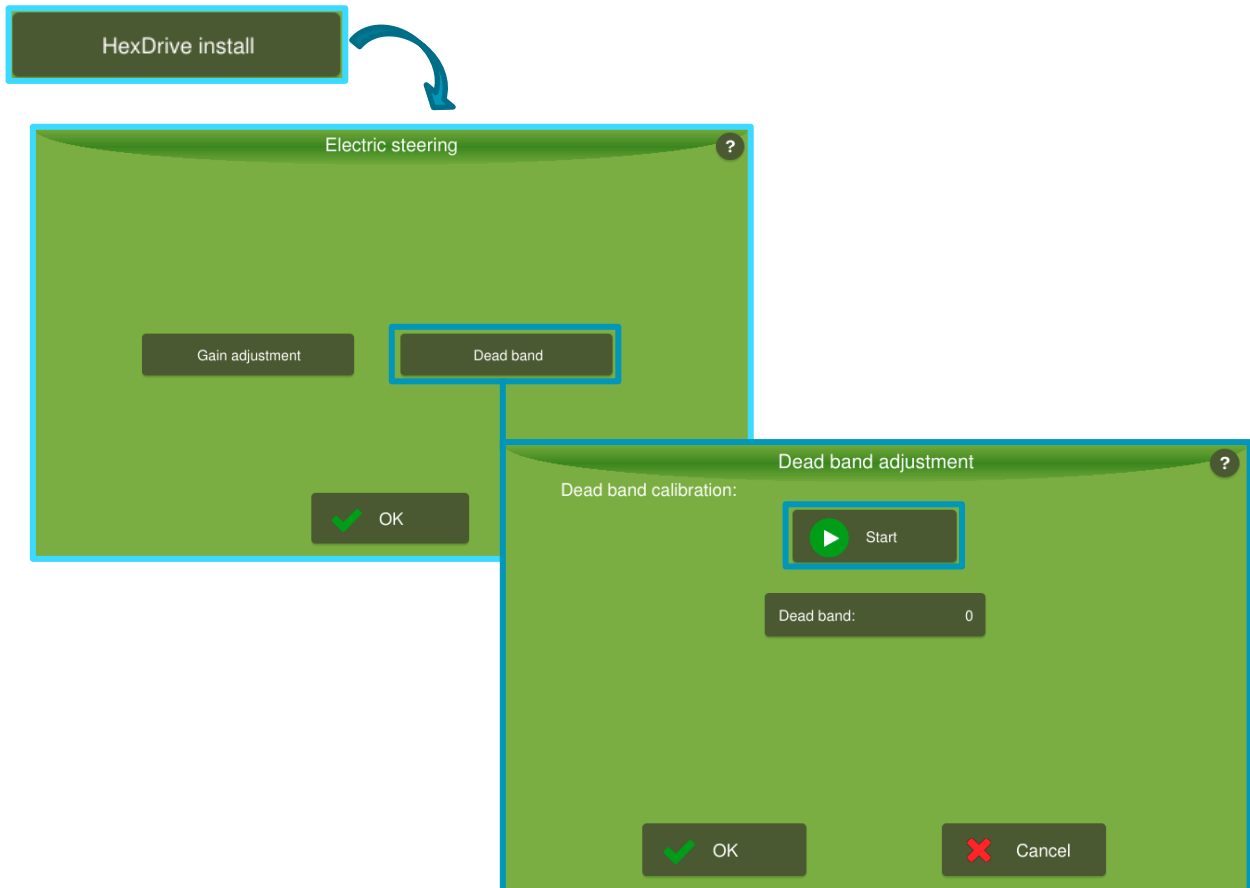

This test identifies the minimum voltage that must be applied to the actuator in order for the wheels to start moving:

- 01-** Align the wheels with the main axis of the tractor (wheels should be pointing straight forward)
- 02-** Press **Start** and wait until the finish test, the value in the Dead Zone field will be modified to the calibrated value and the Start button will have its modified state.

WARNING Do not use the steering wheel or change the wheels position during the test.

WARNING Make sure that the area around the steering wheel is free. During this test, the steering wheel may make sudden movements and hurt the operator if he is next to or touching the steering wheel

IMPORTANT The value obtained for the Dead Band after calibration, is around 150. It is recommended to retake the test if the value is very different

5.4.2 HexDrive Installation Gain Adjustment

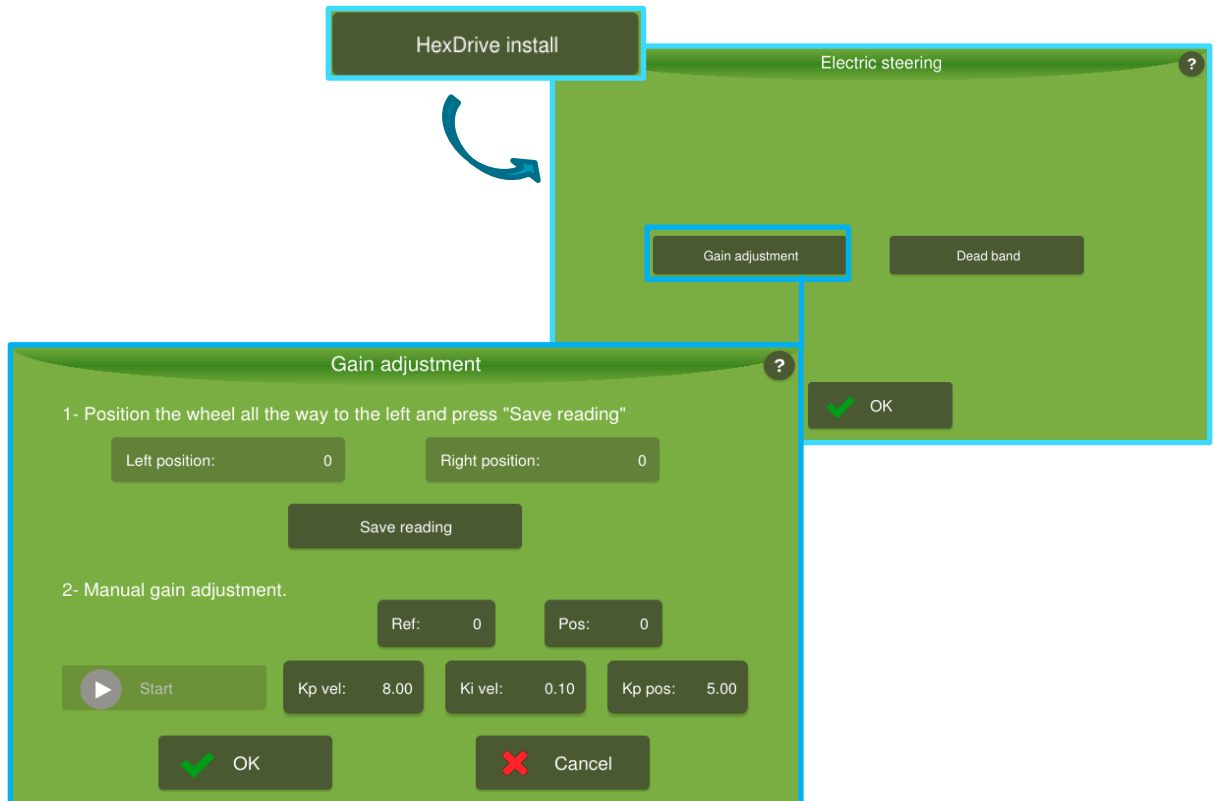

Tests the actuation and performs the motor position control setting

- 01-** Position the wheel all the way to the left and press **Save reading**;
- 02-** Position the wheel all the way to the right and press **Save Reading**;
- 03-** Enter **Ref** with an average value between the left and right position;
- 04-** Tap **Start** to activate the test
- 05-** Change the value of the **Ref** to positive and negative values and observe the response.
Example: If the left position reading was -260 you can enter a **Ref** value of -220, press start and see if the vehicle steers to the left. You can repeat this process with the values of the right position.
 - For each pulse variation the autopilot has to respond. If you happen to vary greatly (0-10) for the autopilot begin to respond it is necessary to change the value of **Kp. Vel.** so that the motor becomes faster and it begins to pulse control pulse;
 - If the value of **Kp. Vel.** is too high the wheel will be tremendous and;
 - it is necessary to reduce the amount of gain;
 - If slow response, increase the value of **Kp Pos**;
 - If high position error (difference values of fields **Ref** and **Pos**) increase the value of **Kp Pos**;
 - If overshoot or high instability system, reduce the value of **Kp Pos**.
- 06-** At the end of the test, the read value of the field **Ref**. has to match the position.

5.5 INS Installation

The values shown in the following screen depend on the current position of your tractor:

NOTE: these values are going to be collected during the calibration steps ahead. There is no need to do these tests right now.

01 – Typical values up to 2,0000.

02 – Typical values up to 10,00.

INS install

INS installation ?

Roll:	2.83		<div style="background-color: #f44336; color: white; padding: 5px; border-radius: 5px; display: inline-block;"> ■ Stop </div>
Pitch:	-3.03		
Yaw:	180.00		

Gyro X:	0.0000	<div style="border: 2px solid orange; border-radius: 50%; width: 30px; height: 30px; display: flex; align-items: center; justify-content: center; margin: 0 auto;"> 01 </div>
Gyro Y:	0.0000	
Gyro Z:	0.0000	

Roll offset (degrees):	0.00	<div style="border: 2px solid blue; border-radius: 50%; width: 30px; height: 30px; display: flex; align-items: center; justify-content: center; margin: 0 auto;"> 02 </div>
Pitch offset (degrees):	0.00	

✓ OK

✗ Cancel

- 01-** Position the tractor horizontally and click **Start**
- 02-** Tilt the tractor to the right. Reading **Roll** should go to a negative value turning to the left, reading **Roll** should go for a positive value

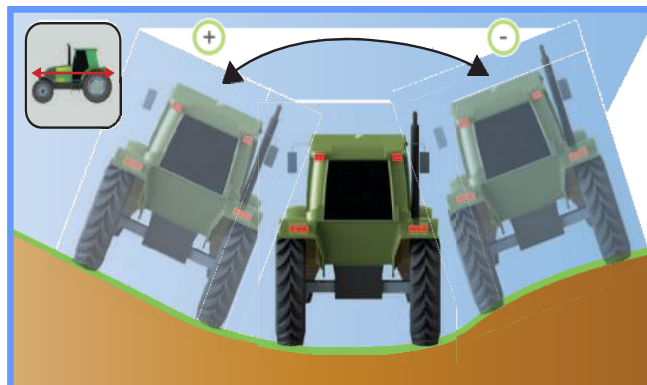

- 03-** Turn the tractor forward. The **Pitch** reading must be a negative value. Turn back so that the Pitch reading is a positive value

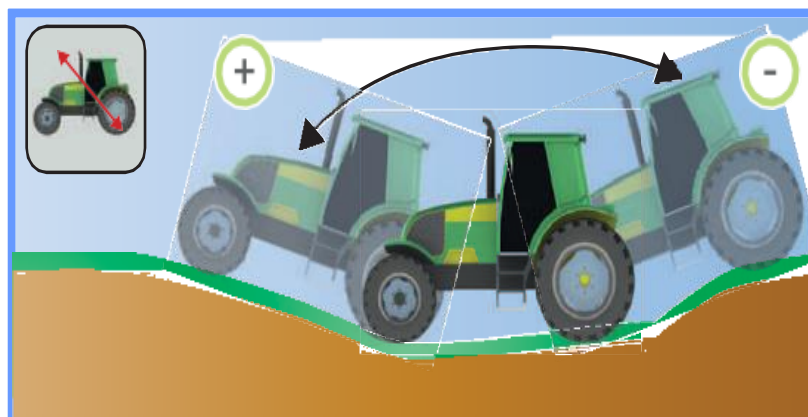

04- The **Yaw** reading will only be different from zero with the moving vehicle

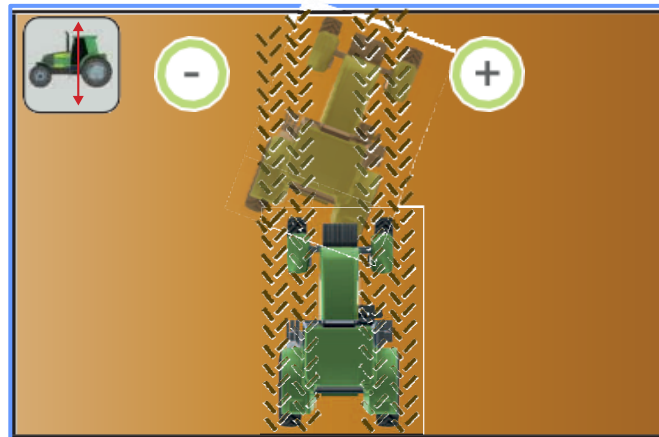

Clockwise: +
Counterclockwise: -

WARNING

Check if the value shown when leaving the tractor stopped quickly stabilizes and there is no overrun (go to a high reading and then go decreasing), if it occurs, or there are differences in values read, check for problems on the driver assembly or any defective component.

5.6 Calibration

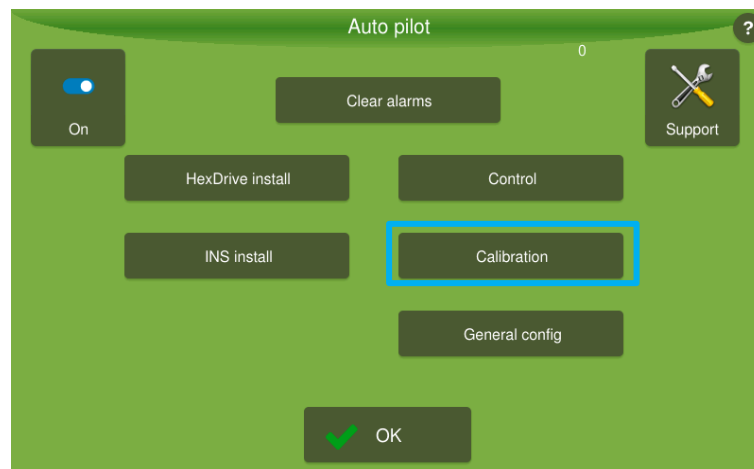

In the calibration screen, it is possible to set the following parameters of the equipment:

- Position of the Driver (ATCD);
- Relative position between the driver and the vehicle control;
- Bias Gyroscope;
- Bias Gyroscope;

5.6.1 Driver Calibration

Informs to the display Ti, the installation position of the driver control.

Before starting the test, watch out the following facts:

- Do not rock the vehicle during this step;
- As the test is performed in two steps, it is necessary to move the vehicle and it is advised to make markings on the floor so the testes are carried out without changing too much the prominent soil characteristics;
- Perform the tests at a flat level;
- Whenever the driver has been removed from its position (either for cleaning or any other purpose) this step must be redone, even if the device has been set in the same location.

 **WARNING**

Choose the correct position of the driver opening more options where we  read: **1-Horizontal front** select the option that is in accordance with the installation and press **Next**. See the example below:

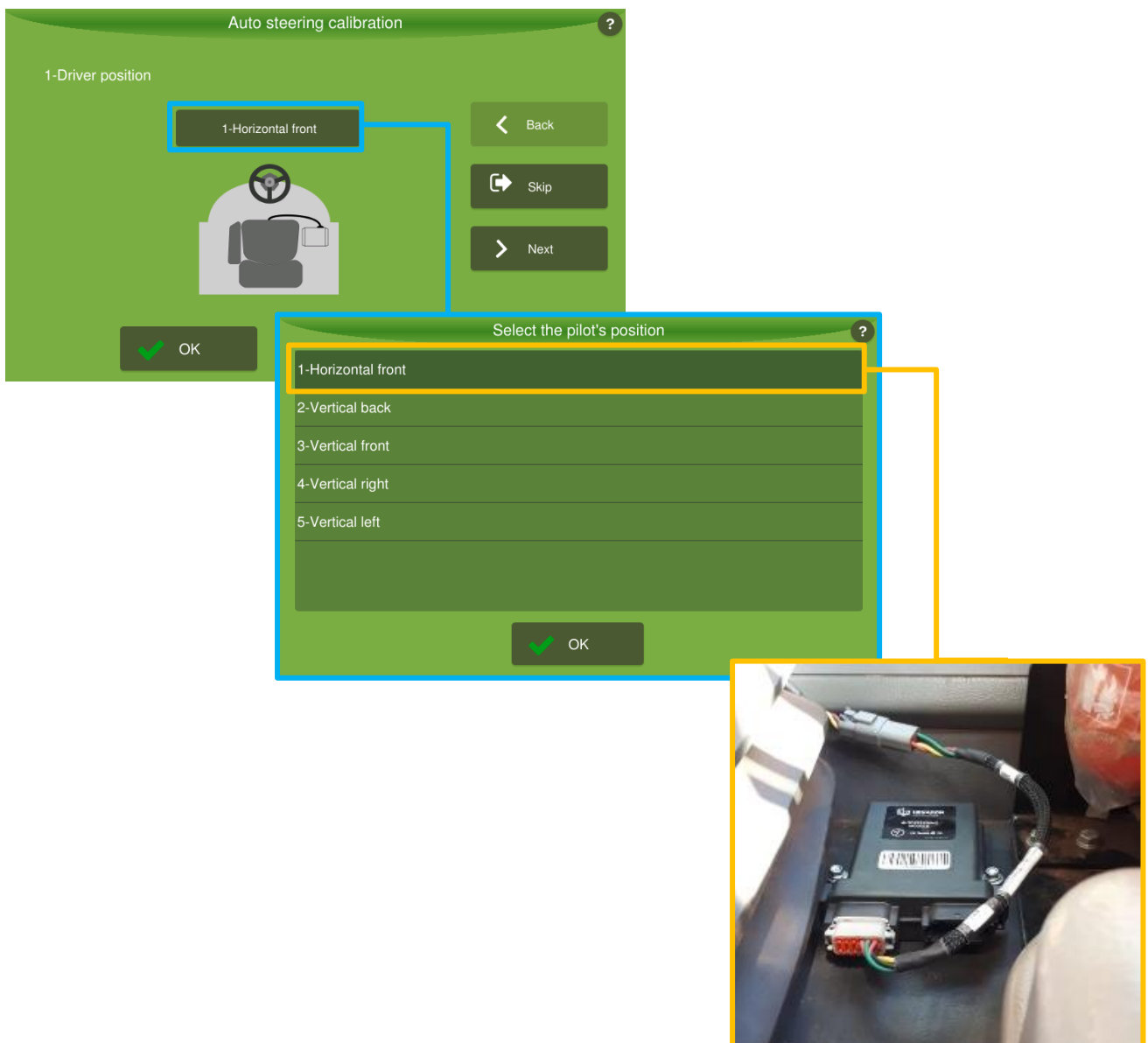

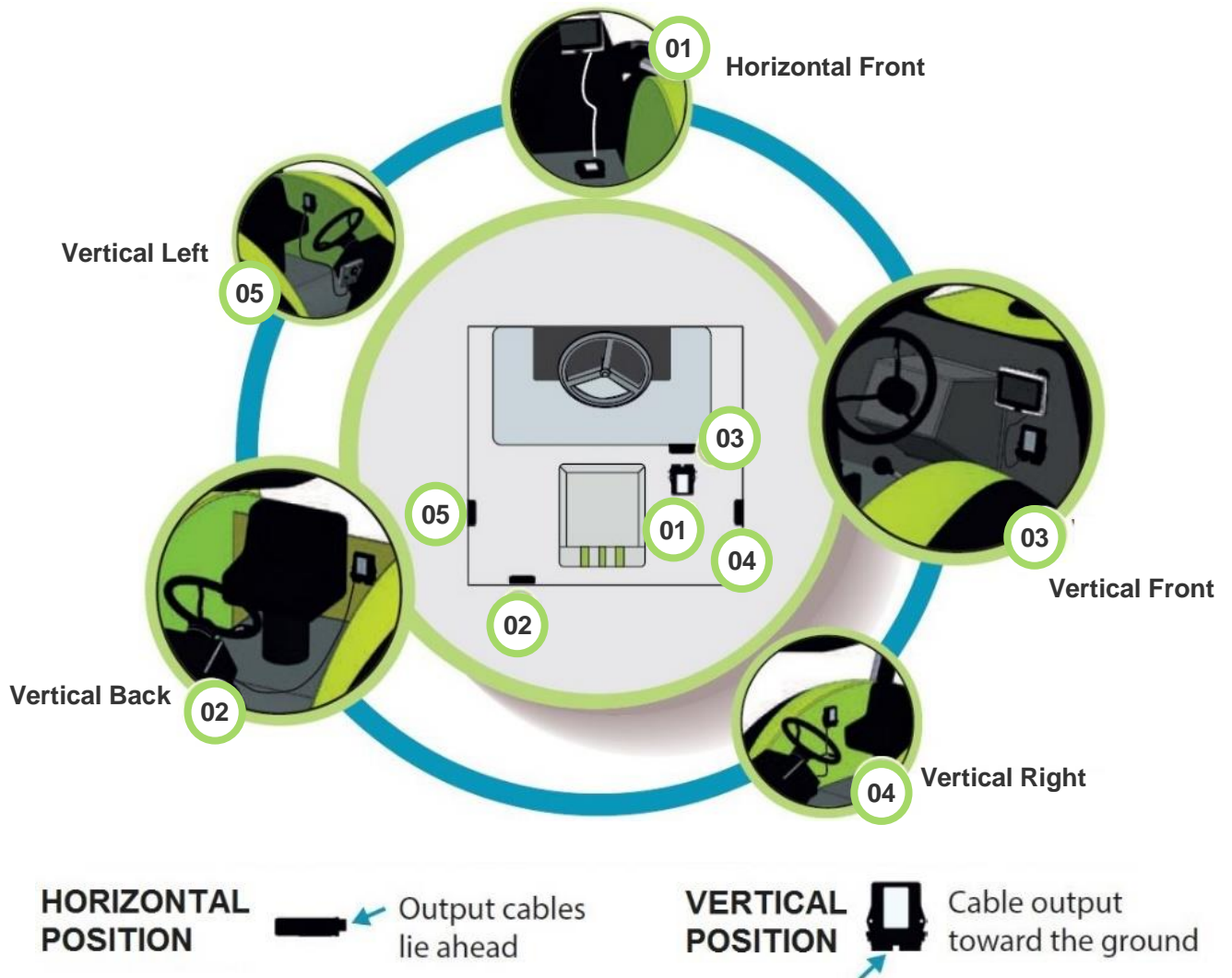

5.6.2 Accelerometer Calibration

Determines the relative position (roll and pitch angles) between the vehicle and the position of driver installation.

 **WARNING**

Perform the test with the engine at operating speed.

Do not rock the vehicle during this step.

Do not move the vehicle during the test.

Perform the test at a flat level.

If the result shows any angle (roll or pitch) with more than 10 degrees, it is recommended, reassess the installation position (the slope compensation cannot operate as expected)

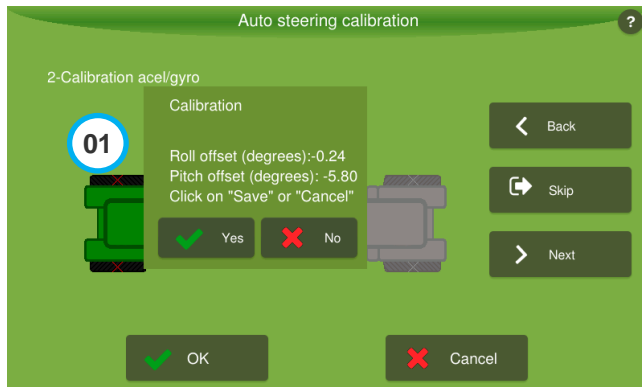

- 01-** Raise the engine RPM to the working speed (1500-2000rpm);
- 02-** Tap the left tractor image (01) and wait 10 seconds;
- 03-** Wait for the tractor image on the right to be enabled (green), mark the ground where the center of the four wheels of the vehicle are;
- 04-** Maneuver the vehicle and come back to the same spot, putting the front wheels where the rear wheels were before, and the rear wheels should be placed where the front wheels were previously;
- 05-** Press the right tractor image (2) and wait for 10 seconds;
- 06-** Once both images are green, a window appears showing the values found. Press **Yes** to save and press **Next**.

5.6.3 Gyroscope Calibration

Aims to estimate errors present in the data provided by the gyroscope

WARNING

Perform the test with the engine at operating speed.

Do not rock the vehicle during this step.

Do not move the vehicle during the test.

Perform the test at a flat level.

If the result shows any angle (roll or pitch) with more than 10 degrees , it is recommended , reassess the installation position (the slope compensation cannot operate as expected)

Do Not make any movements during the execution of this step

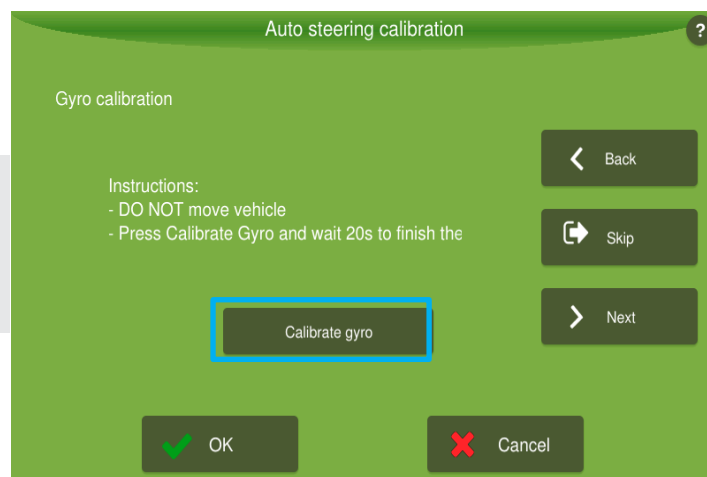

How to proceed:

- 01- Press the Calibrate Gyro button and wait until the bar that will appear gets full;
- 02- After 20 seconds, a window will appear with the values found. Confirm with OK to save this step

5.6.4 Wheels Alignment Calibration

How to proceed:

NOTE: In this level, all four steps are done pressing the same button, that will update new info according to the sequence. Save reading (center) > Save reading (left) > Save reading (right) > Test Commands.

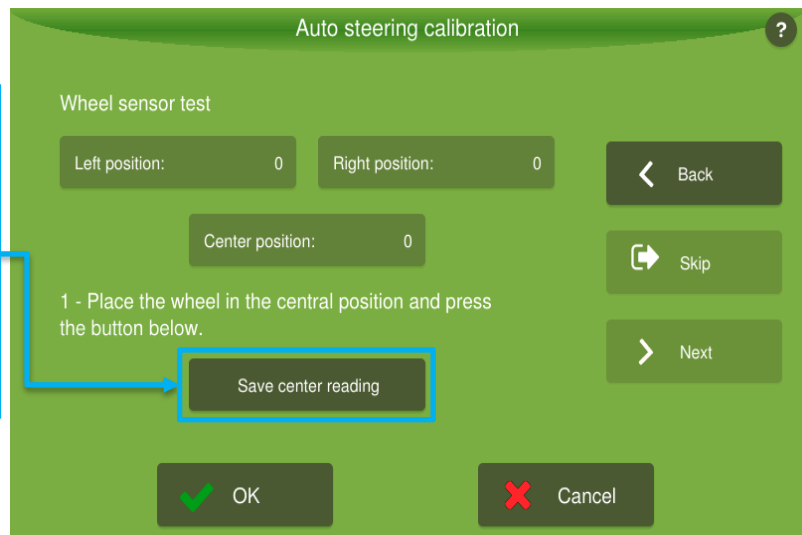

- 01- Place the vehicle with the wheels aligned forward with the vehicle still. Make sure to see if the wheels are aligned straight forward. After aligning the wheels, press **Save Center Reading**;
- 02- Steer the wheels all the way to the left and press **Save Left Reading**;
- 03- Steer the wheels all the way to the right and press **Save Right Reading**;
- 04- Afterwards, put the wheels back in the central position, so that que system will be enabling a new option in this field to test the actuation. Let the steering wheel free and press **Test commands**;
- 05- Press the **Next** button to continue with the calibration procedure.

5.6.5 Clockwise and Counter Clockwise Calibration

 **WARNING**

Before starting the test, watch for the following facts:
 Clockwise means performing an entire circle to the right, counter-clockwise an entire circle to the left.

 **IMPORTANT**

This step requires that the vehicle is in motion, a large area is required, without obstacles for its completion.

Clockwise calibration

- 01- With the vehicle moving and the steering wheel all the way to the right, press **Start**, for the system to start recording the data;
- 02- At the end of the test, Press **Next**.

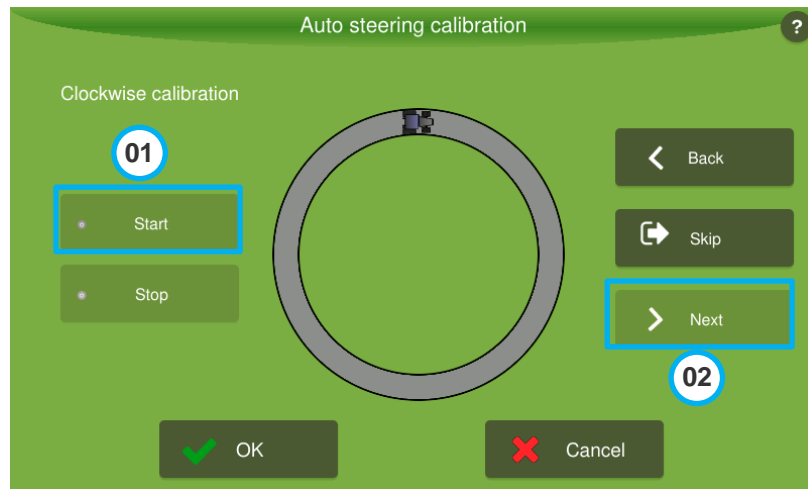

Counter clockwise calibration

- 01-** With the vehicle moving and the steering wheel all the way to the left, press **Start**, for the system to start recording the data;
- 02-** At the end of the test, the result appears showing the motor/wheel gain, it must be between 400 and 700, click **Yes** to store the data;

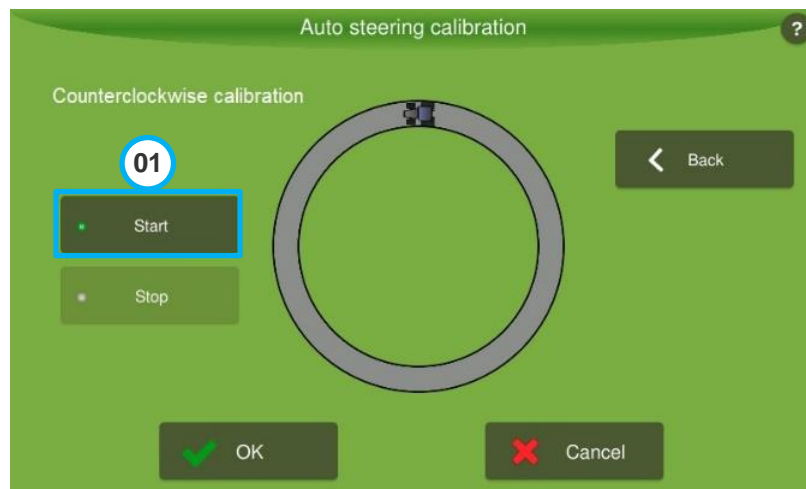

- 03-** After saving the value for relation motor/wheel, press **OK** to save the whole process of calibration

5.7 Autopilot General Configurations

In Auto pilot, enter go to **General config**, for settings of safety and operation parameters of the electric autosteering system.

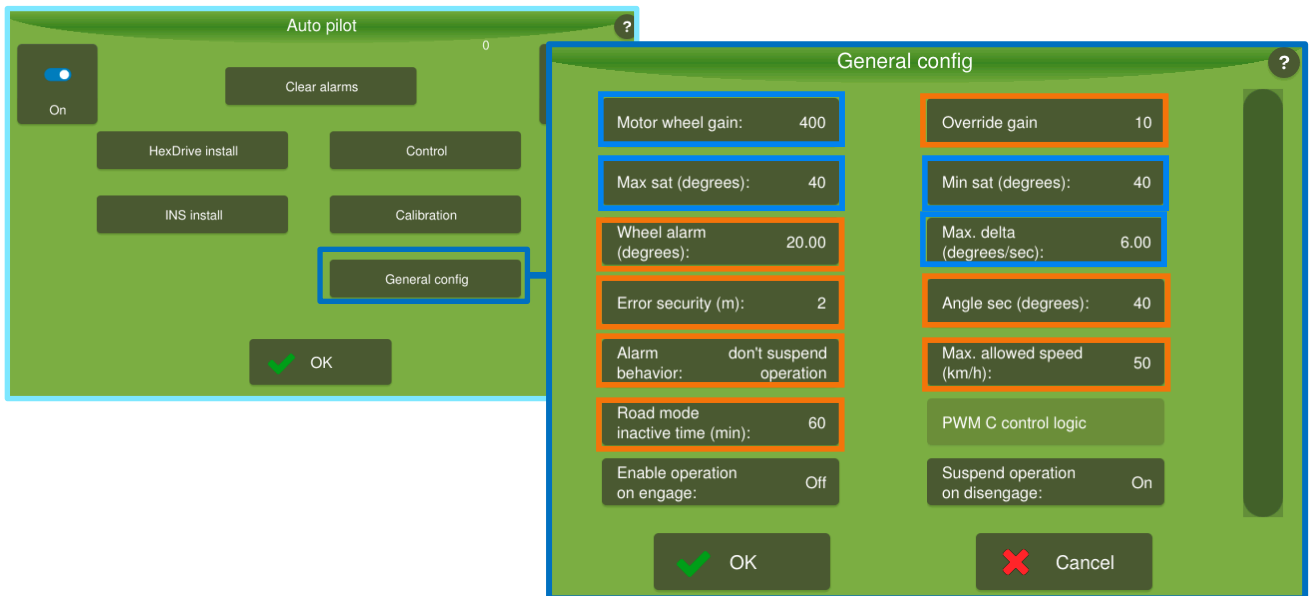

■ Safety parameters ■ Operation parameters

Safety parameters:

- **Wheel alarm:** Checks the functioning of the wheel sensor (Hexdrive motor), in case of anomaly, deactivates the autopilot.
- **Error security:** Locks the driver's use if the error is above the set value.
- **Alarm behaviour:** Indicates whether the autopilot's alarms will suspend the operation or not (section cutting, fertilizing, etc.).
- **Road mode inactive time:** Corresponds to the time configurable by the operator for the pop up warning to appear. This warning is for autopilot downtime.
- **Override gain:** Parameter for manual disarm setting of the equipment (operator acting as a director with the equipment on). It varies from 6 to 12, being 12 the strongest resistance against the disarm.
- **Angle sec (degrees):** Blocks the use of autopilot, if the angular error in relation to the guideline is above the set up value.
- **Max. allowed speed:** Corresponds to the value that the user wants to use as the cutting speed in the operation. If the equipment is operating above the configured maximum speed, it will not be possible to turn on the autopilot. If the equipment exceeds the maximum speed, with the autopilot on, it will be disarmed.

Operation parameters:

- **Motor wheel gain:** after calibration, the expected value is going to be between 300 and 700, lower vehicle dimensions means lower values.
- **Sat Max:** maximum steering angle at low speeds.
- **Sat Min:** maximum steering angle at high speed (25km/h).

- **Delta Max:** Wheels steering speed.
- **Enable operation on engage:** If on, starts application/painting when autopilot is engaged.
- **Suspend operation on disengage:** If on, stops the application/painting when autopilot is disengaged.

 **WARNING**

Low values for these parameters tend to impair the autopilot's entry and response in the curved guideline (slowness to perform maneuvers)
 High values of Sat Min and Delta Max can cause sudden movements of equipment, which affect the safe operation at high speeds.

5.8 Controls

Parameters that are required for better performance of the autopilot, allowing it to better perform in different field conditions and operations. They are **Overshoot**, **Aggressivity**, **Sensibility**, **Speed gain (%)** and **Curve aggressivity**.

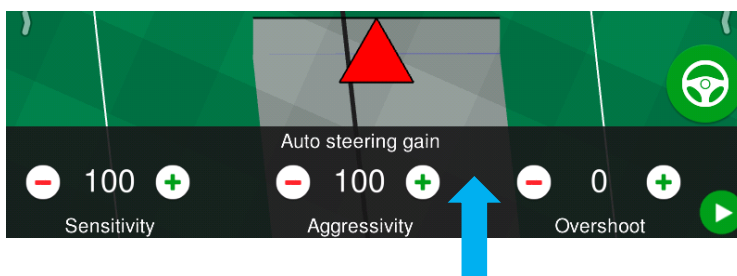
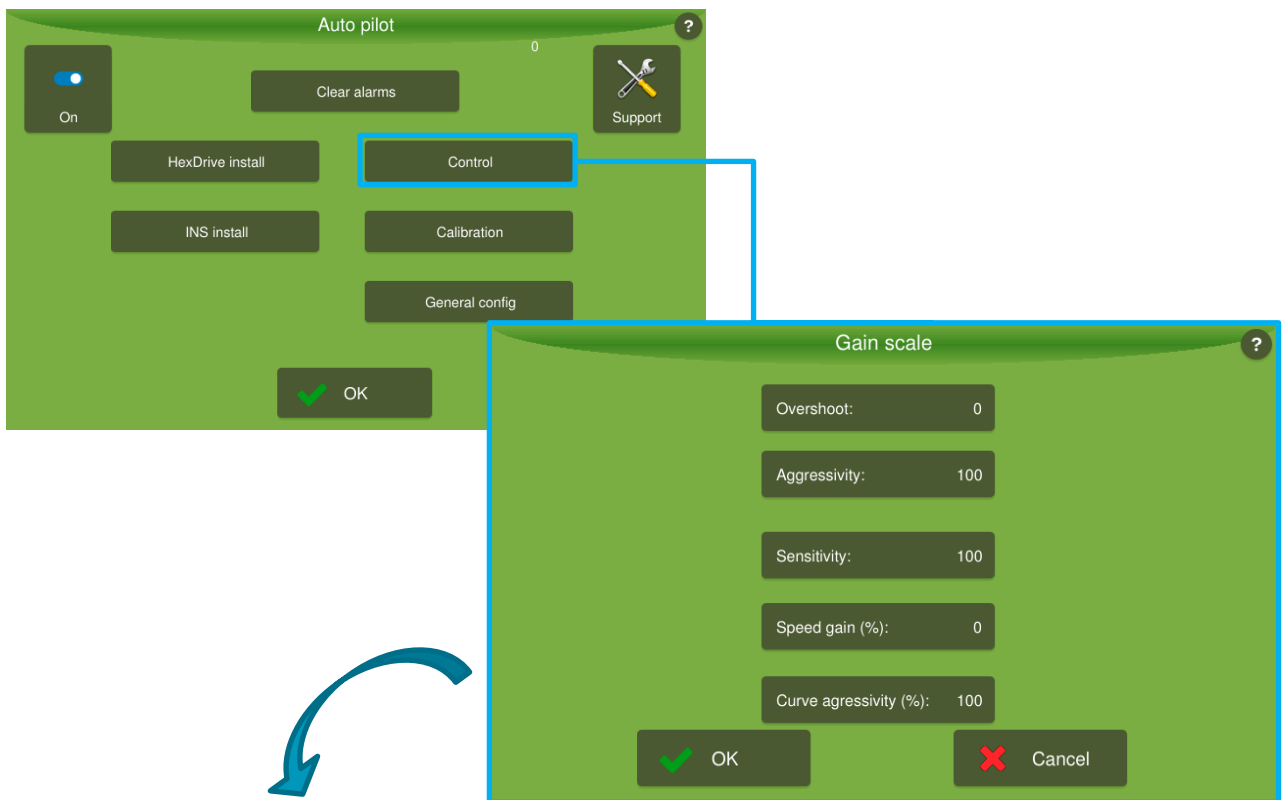

On the operation screen, scrolling from the bottom to the middle, as shown in the picture beside, it is also possible to access the main parameters: **Sensibility**, **Aggressivity** and **Overshoot**.

5.8.1 Overshoot

The **Overshoot** controls the rate that the vehicle will drive at the wayline and the rate that the vehicle will end as it approaches the wayline. The default value is zero, and must change it only if you cannot eliminate the over signal through the Aggressiveness and Sensitivity.

Parameter ranges from 0 to 200 (default value 0 - disabled).

A high value tends to make the autopilot to attack the wayline more aggressively probably increasing the overshoot.

A low value tends to make the autopilot to convert to the wayline more slowly by reducing the overshoot.

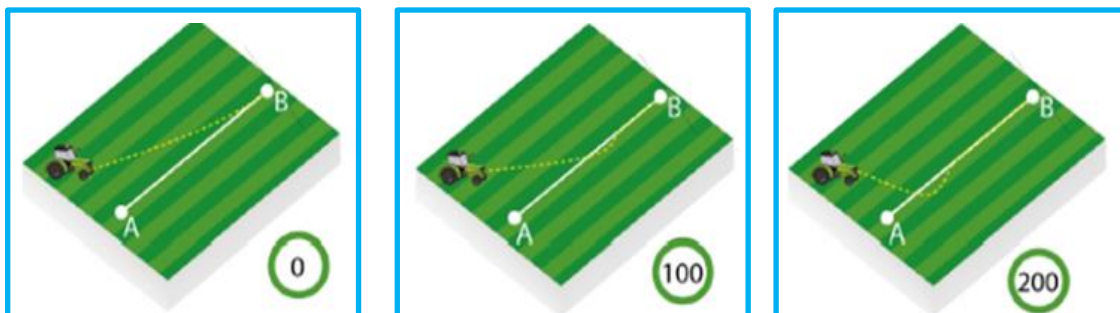

5.8.2 Aggressiveness

Aggressiveness controls the rate at which the vehicle attacks the wayline and how well it stays on the wayline. It can be set between 0 and 200. The default setting is 100. It acts mainly when engaging a guideline.

A high value tends to cause the autopilot to control in zigzag.

A low value tends to cause the autopilot to quickly align; and slowly converge the error to zero.

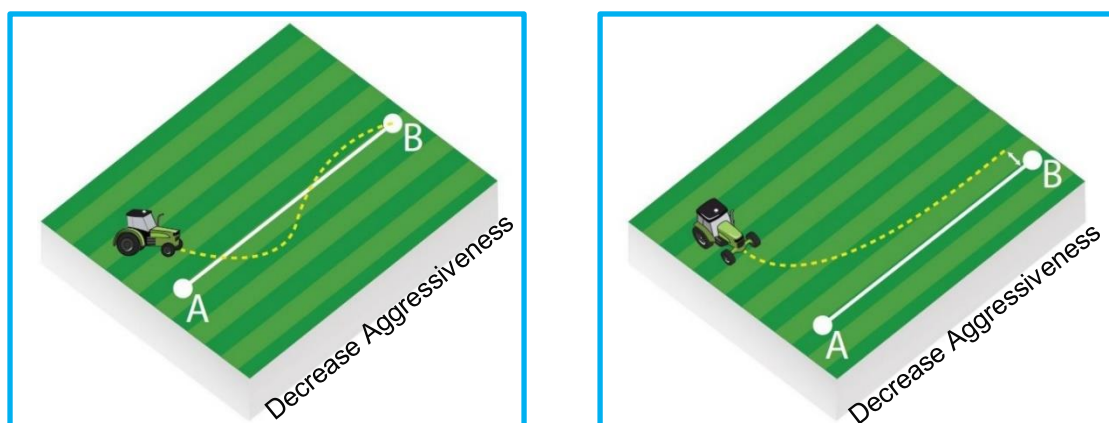

5.8.3 Sensitivity

The **sensitivity** controls the rate at which the vehicle turns and its sensitivity when it is on the line. It mainly acts when already following the guideline.

A high value tends to cause the autopilot to respond quickly to small variations on the ground (balance, etc.) which can cause steer in zigzag acting too much on the wheels.

A low value tends to cause the autopilot to take longer to respond to error variations.

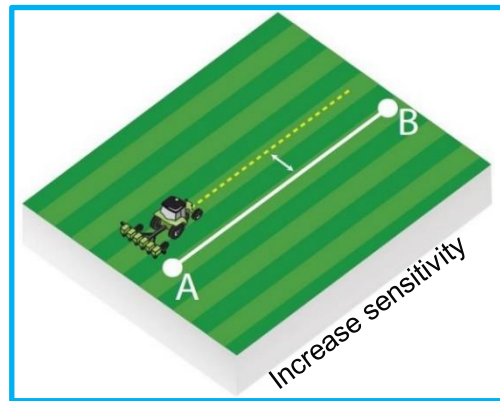
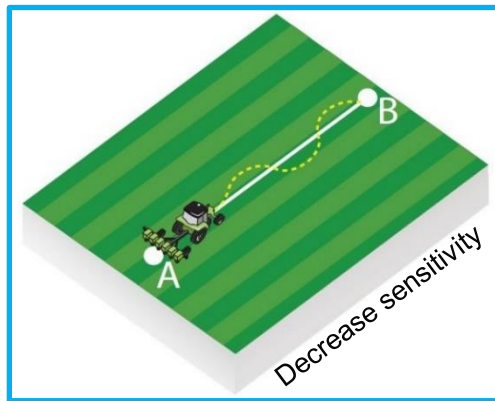

5.8.4 Speed Gain (%)

Altered only in special cases. Standard value = 0

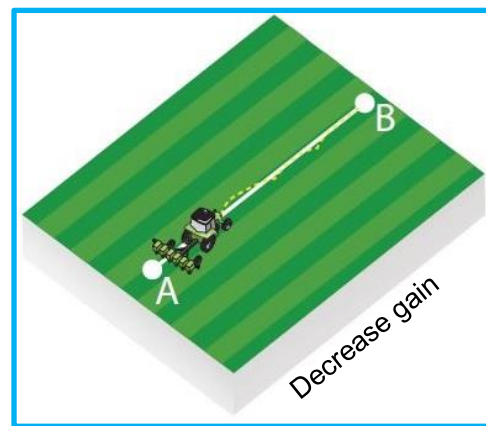
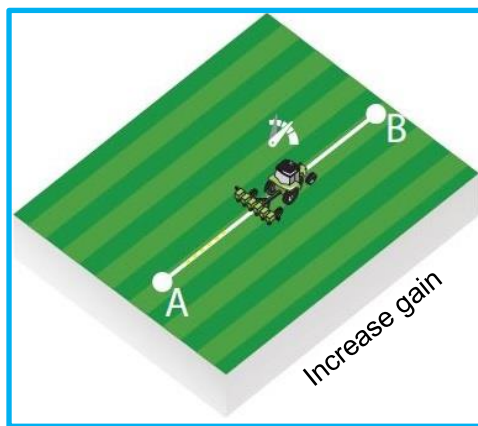

5.8.5 Curve Aggressivity

Assists in setting in the segment of curved paths. Parameter ranges from 0 to 200 (default value 100).

A high value tends to cause the autopilot to make turns tighter than necessary, in addition to moving the wheels sharply.

A low value tends to cause the autopilot to make the curve wider than it should by moving the wheels smoothly.

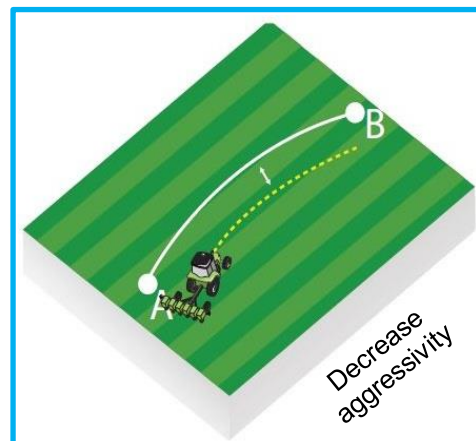
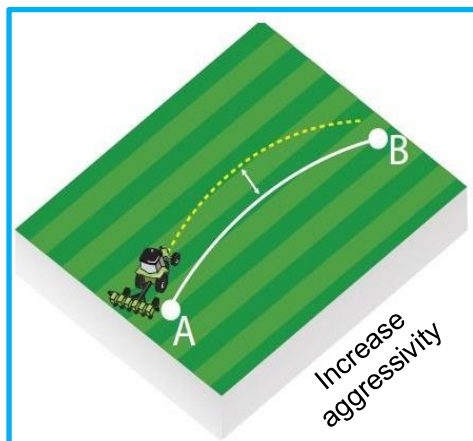

5.8.6 Techniques and Recommendations for Adjustment

01- Note entry (linear guide):

Actuate the autopilot, after being properly calibrated with factory gains.

Aggressiveness:100

Sensibility:100

Overshoot: 0



WARNING Perform the adjustment next to the operating speed.

Field	Description
In case of oscillatory response, zigzag path, aggressive response (moving the wheels quickly) or crossing the wayline too much (> 30 cm).	Reduce aggressiveness and Sensitivity together until you get a stable and safe response.
In case of slow response, slow convergence to zero error, alignment away from the reference wayline.	Increase aggressiveness and sensitivity together until you get a satisfactory response.

02- Aggressiveness and sensibility settings:

After obtaining a stable and secure response to the input, adjust the aggressiveness and sensibility, separately, to get the best possible performance.

Increase aggression for greater 'attack' to the wayline during entry. If the autopilot is too aggressive or with high overshoot, reduce the parameter.

During operation over the wayline, if the autopilot is acting too much on the wheels, tending to a zigzag path, reduce the sensitivity value.

If taking a long time to respond to slope terrain variations, tendency to go parallel with the wayline - error > 1 cm-, increase the sensitivity.

03- Overshoot adjustment:

If the autopilot still has overshoot when entering the wayline, adjust the overshoot.

Difficult to reconcile a good entry with a good response on the row: - change the overshoot value from 0 to 100.

If the overshoot is still high, reduce the value.

If the autopilot has lined up away from the wayline, increase the value.

04- Curve gain:

First, aggressiveness and sensibility must be adjusted when operating on a linear guide.

If the trajectory is always wider than the reference, increase the gain.

If the trajectory is always closer than the reference, reduce the gain.



WARNING

The values of Sat Max, Sat Min and Delta Max (available in the General Settings menu) directly affect the response to the guide curve.

Low values for these parameters tend to slow down the response. Raising the gain curve, in this case, improves performance.

6 Operation





6.1 Autopilot Status

In the operation screen, make sure the icon is active.

i IMPORTANT If the icon is disabled, select Menu> Autopilot and check icon on the top left hand side is indication **On**.

To engage the autopilot, press **Power** in the operation screen.

To turn it off, press the same button, force the steering wheel by hand to disengage the Autopilot or use the foot switch to turn it on/off.

Icon	Description
	Autopilot is engaged - equipment is on and controlling the steering.
	Enabled autopilot – Equipment is ready for operation.
	Blocked autopilot - Equipment cannot be engaged. Critical alarm occurrence (which prevents operation). Error and angle relative to the elevated guide.
	Pilot unavailable - autopilot without communication with the ECU.

7 Problems and Solutions

Problems	Causes	Solutions
Problem 1 Equipment does not turn on.	Poorly fitted power connector.	Fit the connector correctly.
	Blown up/poorly connected power harness fuse.	Check the fitting and replace the fuse if it is blown up.
	Inverted battery wires.	Fix the wires correctly: red (with fuse holder) on the positive pole and black on the negative pole.
	Battery voltage too low.	Replace battery/alternator maintenance.
	Broken or short-circuited power harness.	Preferably, replace harness or repair it.
Problem 2 GPS Alert Synchronizing.	Condição atmosférica.	Aguardar condição favorável.
	Antenna not visible to the open sky.	Place the antenna free of obstacles, such as a shed or trees.
	Defective antenna cable.	Harness maintenance/replacement.
	Defective antenna.	Antenna replacement.
	Defective equipment.	Maintenance in technical assistance.
Problem 3 GPS No Communication Alert.	Wrongly configured communication port.	Configure the port in GNSS.
	Wrong GPS model configured.	Contact Hexagon's technical department.
	Defective GPS board/controller board.	Maintenance in technical assistance.
Problem 4 Frequent loss of GPS signal.	Ionospheric Flicker.	Avoid using the equipment at times of day when the effect is strongest.
	Very rugged area.	The antenna needs a minimum number of satellites to work properly.
	Antenna too low/incorrect position.	Place the antenna on the tractor roof, on the longitudinal center line.
	Bad contact in the antenna cable.	Cable maintenance/replacement.

Problems	Causes	Solutions
Problem 5 Autopilot does not improve response by modifying gains.	Changing aggressiveness and sensitivity does not improve performance.	Problem in the mechanical installation or configuration of the equipment.
	Autopilot exhibits the same behavior with high or low gains.	Check vehicle configuration.
		Check operation of inertial sensors (INS - INS Installation menu).
		Check if the driver (ATCD) is screwed correctly.
Problem 6 Error is not reset.		Check the operation of the Hexdrive Motor and the anti-rotation bracket.
		Check operation of inertial sensors (INS - INS Installation menu).
		Check if the driver (ATCD) is screwed correctly.
Problem 7 Nothing happens after starting the HexDrive installation test.		Check if the driver is recognized on the network (Menu Information > Network diagnostics). If it is not found, check power supply as well as cable continuity.
Problem 8 Problems with the autopilot		Check anti-rotation attachment.
		Check flange fitting.
		Check autopilot driver attachment.
		Check HexDrive harness
Problem 9 Does not read PITCH values.	Problem on the Driver	Replace equipment.
Problem 10 Does not read ROLL values.	Problem on the Driver	Replace equipment.